

USER MANUAL

Thank you for purchasing our products, please take some minutes to read this manual before operating any of these laser projectors!

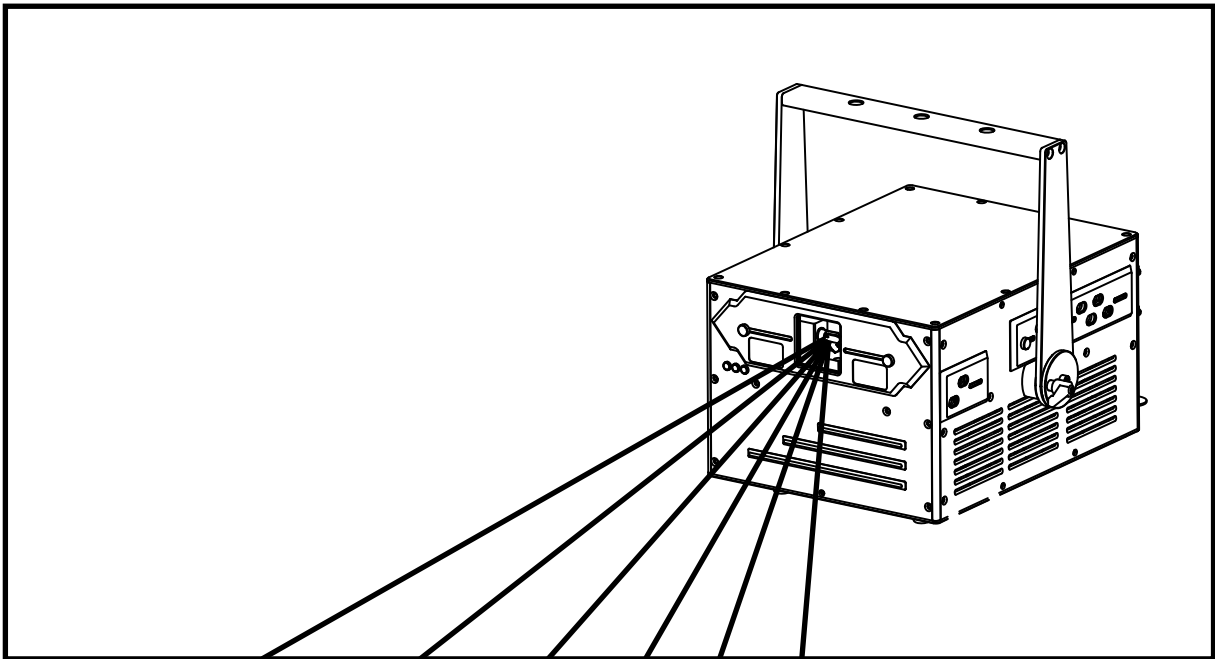

PR3000A-RGB
PR4000A-RGB
PR5000A-RGB
PR5500A-RGB
PR6000A-RGB
PR8000A-RGB

PR9000 - RGB
PR10000-RGB
PR13000-RGB
PR14000-RGB

CF20000-RGB
CF24000-RGB
CF30000-RGB

Notice
AVOID EYE OR SKIN EXPOSURE TO
DIRECT OR SCATTERED LIGHT
CLASS 4 LASER PRODUCT

Manufactured/ Certified by
Shenzhen Optlaser Technologies Co.,Ltd
www.optlaser.com

Content

INTRODUCTION	- - - - -	2
PACKING LIST	- - - - -	2
UNPACKING INSTRUCTIONS	- - - - -	2
GENERAL INFORMATION	- - - - -	2
<i>SAFETY NOTES</i>	- - - - -	3
LASER AND SAFETY NOTES	- - - - -	4
LABELLING REFERENCE	- - - - -	5, 6
PROPER USAGE	- - - - -	7
RIGGING	- - - - -	7
OPERATIONS	- - - - -	8, 9
INTERLOCK DIAGRAM	- - - - -	10
LCD Display Setting introductions	- - - - -	11-15
PR5 SERIES	- - - - -	16
INTRODUCTIONS of PR5 SERIES	- - - - -	17
Specifications of PR5 SERIES	- - - - -	18
PR10 SERIES	- - - - -	19
INTRODUCTIONS of PR10 SERIES	- - - - -	20
Specifications of PR10 SERIES	- - - - -	21
CF20 CF30 SERIES	- - - - -	22
INTRODUCTIONS of CF20 CF30 SERIES	- - - - -	23
Specifications of CF20 CF30 SERIES	- - - - -	24
Display mode introduction	- - - - -	25
DMX CHART	- - - - -	26, 27
INTRODUCTIONS OF RE-ALIGNMENTS. REF.	- - - - -	28
Maintenance Instruction	- - - - -	29

INTRODUCTION

Thank you for purchasing our products. To optimize the performance of your laser, please read these operating instructions carefully and familiarize yourself with the basic operations of this system. These instructions contain important safety information regarding the use and maintenance of this system as well. Please keep this manual with the unit, for future reference. If you sell this product to another user, be sure that they also receive this document.

Notice

- We are constantly striving to improve the quality of our products. As such, the content of this manual may be changed without notice.
- We have tried our best to guarantee the accuracy of this manual. If you have any questions or find any errors, please contact us directly to help correct this.

PACKING LIST

Name	Qty(pcs)
LASER projector	1
AC power cord	1
Keys for Key switch	2
Power output connector	1
Remote Interlock connector	2
Allen key	1

UNPACKING INSTRUCTIONS

Open the package and carefully unpack everything inside.

Ensure all parts are present and in good condition.

Do not use any equipment that appears to be damaged.

If any parts are missing or damaged then please immediately notify your carrier or local distributor.

GENERAL INFORMATION

The following chapters explain important information about lasers in general, basic laser safety and some tips about

how to use this device correctly. Please read this information as it contains critical information you must be aware of, prior to using these system.

SAFETY NOTES

WARNING! These projectors are Class 4 laser products. It must never be used for audience-scanning applications. The output beam of the projector must always be at least 3 meters above the floor in the audience. See the Operating Instructions section for further information.

Please read the following notes carefully! They include important safety information about the installation, usage, and maintenance of this product.

- Keep this User Manual for future consultation. If you sell this product to another user, be sure that they also receive this document.
- Always make sure that the voltage of the outlet to which you are connecting this product is within the range stated on the decal or rear panel of the product.
- This product is not designed for use outdoors in adverse weather conditions. To prevent risk of fire or shock, do not expose this product to rain or moisture.
- Always disconnect this product from the power source before cleaning it or replacing the fuse.
- Make sure to replace the fuse with another of the same type and rating.
- If mounting it overhead, always secure this product to a fastening device using a safety chain or cable.
In the event of a serious operating problem, stop using the projector immediately. Never try to repair the unit except in a controlled environment under trained supervision. Repairs carried out by unskilled people can lead to damage or malfunction of the unit, as well as exposure to dangerous laser light.
- Never connect this product to a dimmer pack.
- Make sure the power cord is not crimped or damaged.
- Never disconnect the power cord by pulling or tugging on the cord.
- Never carry a product from the power cord or any moving part. Always use the hanging/mounting bracket or the handles.
- Always avoid eye or skin exposure to direct or scattered light from this product.
- Lasers can be hazardous and have unique safety considerations. Permanent eye injury and blindness is possible if lasers are used incorrectly. Pay close attention to each safety REMARK and WARNING statement in this user manual. Read all instructions carefully BEFORE operating this device.
- Never intentionally expose yourself or others to direct laser light.
- This laser product can potentially cause instant eye injury or blindness if laser light directly strikes the eyes.
- It is illegal and dangerous to shine this laser into audience areas, where the audience or other personnel could get direct laser beams or bright reflections into their eyes.
- It is a US Federal offense to shine any laser at aircraft.
- No service allowed by customer. There are no user serviceable parts inside the unit. Do not attempt any repairs yourself.
- Service is only to be handled by the factory or authorized factory trained technicians.
- Product is not to be modified by the customer.
- Caution – use of controls or adjustments or performance of procedures other than those specified herein may result in hazardous radiation exposure.

LASER AND SAFETY NOTES

STOP AND READ ALL THE LASER SAFETY NOTES BELOW

Laser Light is different from any other light sources with which you may be familiar. The light from this product can cause eye and skin injury if not set up and used properly. Laser light is thousands of times more concentrated than light from any other kind of light source. This concentration of light can cause instant eye injuries, primarily by burning the retina (the light sensitive portion at the back of the eye). Even if you cannot feel “heat” from a laser beam, it can still potentially injure or blind you or your audience. Even very small amounts of laser light are potentially hazardous even at long distances. Laser eye injuries can happen quicker than you can blink. It is incorrect to think that because these laser entertainment products use high speed scanned laser beams, that an individual laser beam is safe for eye exposure. It is also incorrect to assume that because the laser light is moving, it is safe. This is not true.

Since eye injuries can occur instantly, it is critical to prevent the possibility of any direct eye exposure. It is not legal to aim this laser projector into areas where people can be exposed. This is true even if it is aimed below people’s faces, such as on a dance floor.

- Do not operate the laser without first reading and understanding all safety and technical data in this manual.
- Always set up and install all laser effects so that all laser light is at least 3 meters (9.8 feet) above the floor on which people can stand. See the “Proper Usage” section later in this manual.
- After set up, and prior to public use, test the laser to ensure proper function. Do not use if any defect is detected.
- Laser Light - Avoid Eye or Skin Exposure to Direct or Scattered Light.
- Do not point lasers at people or animals.
- Never look into the laser aperture or laser beams.
- Do not point lasers in areas where people can potentially be exposed, such as uncontrolled balconies, etc.
- Do not point lasers at highly reflective surfaces, such as windows, mirrors and shiny metal objects. Even laser reflections can be hazardous.
- Never point a laser at aircraft, as this is a US Federal offense.
- Never point un-terminated laser beams into the sky.
- Do not expose the output optic (aperture) to cleaning chemicals.
- Do not use the laser if the housing is damaged, open, or if the optics appear damaged in any way.
- Never leave this device running unattended.
- In the United States, this laser product may not be purchased, sold, rented, leased or loaned for use unless the recipient possesses a valid Class 4 laser light show variance from the US FDA CDRH.
- This product must always be operated by a skilled and well-trained operator who is familiar with the data included in this manual. Note that use of this projector in the United States also requires a valid Class 4 laser light show variance from the CDRH as stated above.
- The legal requirements for using laser entertainment products vary from country to country. The user is responsible for the legal requirements at the location/country of use.
- Always use appropriate lighting safety cables when hanging this projector overhead.

See the following reproductions of the product labels. All these labels must be intact and legible prior to be used on the projector.



Hazard warning symbol

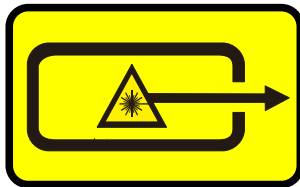

Aperture label

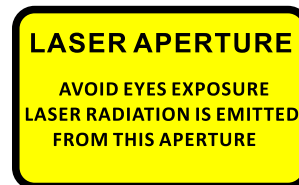

CE RoHS

Note:
Read user manual before use | Operation by qualified personnel only
Never point laser beam at people | Never look into laser beam directly
Any after sales services request, please contact your local authorized dealer or the direct seller for help.

Laser Wavelength(nm):
R 637 638
G 520 532
B 445 450 465

Total Power: _____W
Voltage AC: 100-120V 200-240V 100-240V 50-60Hz
Consumption: _____W
Year:

LASER RADIATION
AVOID DIRECT EYE EXPOSURE
CLASS 4 LASER PRODUCT
DIN EN60825-1: 2015-07

Brand: Optlaser
Model:
MADE IN CHINA

CAUTION OF RADIATION
IF COVER IS MOVED

NEVER AIM AT AIRCRAFT, IT IS UNSAFE AND ILLEGAL
Compliance with IEC-EN60825-1 and 21 CFR 1010.10, 1040.11

PROPER USAGE

This product is for overhead mounting only. For safety purposes, this projector should be mounted on steady elevated platforms or sturdy overhead supports using suitable hanging clamps. In all cases, you must use safety cables.

International laser safety regulations require that laser products must be operated in the fashion illustrated below, with a minimum of 3 meters (9.8 ft.) of vertical separation between the floor and the lowest laser light vertically. Additionally, 2.5 meters of horizontal separation is required between laser light and audience or other public spaces.

The audience area can be passively protected by sliding the aperture cover plate upwards and fixing it in proper position by the two thumb screws.

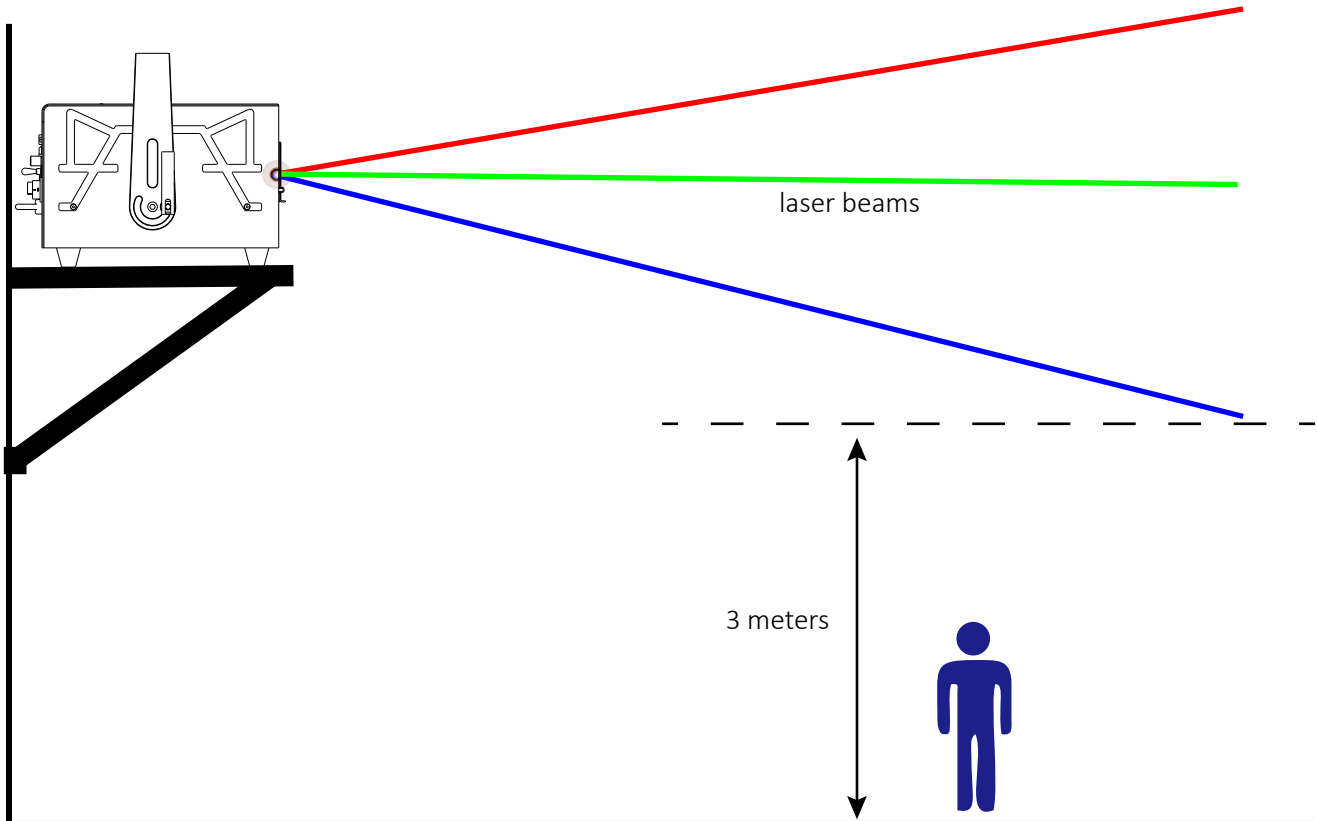

RIGGING

- Be sure that the structure onto which you are mounting this product can support its weight.
- Mount the product securely. You can do this with a screw, a nut, and a bolt. You may also use a mounting clamp if rigging this product onto a truss. The U-shaped support bracket has three mounting holes which may be used to secure the clamps to the projector.
- Always consider ease of access to the unit before deciding on a location for this product
- When mounting this product overhead, always use a safety cable.

Stainless steel cable(safety rope)



OPERATIONS

PR SERIES units come with diode-based only laser sources and all sources have beam correction ,thus have great beam show with analog FULL colors modulation.

The PR SERIES units can be controlled over ILDA and have a built-in memory with preset patterns ,also with TF-card slot for freely programs export onto it, that can be easily triggered by DMX. They can also be operated in automatic.

The laser projector provides a master-slave-mode. Show lasers of the same series (slave projectors), connected via DMX to a main projector (master projector) project the same patterns like the master projector.

This Series will be applicable for clubs, bars, and those Small/medium venues or theater events, parties, business activities, large venues etc.

"PR series projectors are not supplied with standard "E-Stop Box" and "Remote Interlock bypass" Instead, a simplified "E-Stop Box" featured with "Mushroom switch" and "Key switch" will be supplied in the purchase accordingly to request.



The "E-stop Box" is generally with a CAT5 cable of 2m length unless there would be different requests.

If user doesn't need additional "E-Stop Switch", Then the "RJ45 jack interlock connector" should be inserted into the rear plate of the projector's INTERLOCK position(with silkscreen marking) ,only by this way user will be able to light up the laser projector during operations.

Several steps to start up the laser projector(s)

1. Use the included power cord to connect the laser device to a proper power outlet(AC100-240V, 50/60Hz)
2. Use one of the included keys(2 sets included in the package, either one of them will work) to insert into the key-chassis and switch to the "ON" position
3. Use one of the the included INTERLOCK connectors to insert into the INTERLOCK position on the backplate of the device. (2 x RJ45 connectors(well made) included in the package)

Remark: There are 2 positions for INTERLOCK on the backplate of the devices $\geq 10W$ herein, either one of the positions will work(one only position needs to be with INTERLOCK connector inserted if the laser projector will be used alone. Both INTERLOCK positions will work if user wants to daisy chain 2 or more laser projectors through **E-stop box**.

4. Turn on the power switch from  to , then the laser device will start output laser light.

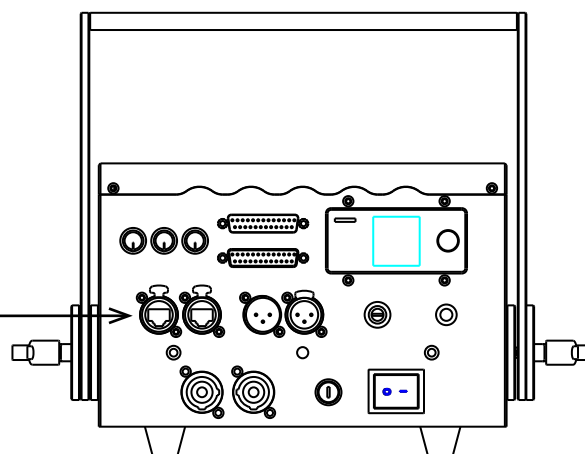

Dual INTERLOCK connections

INTERLOCK CONNECTION DIAGRAM

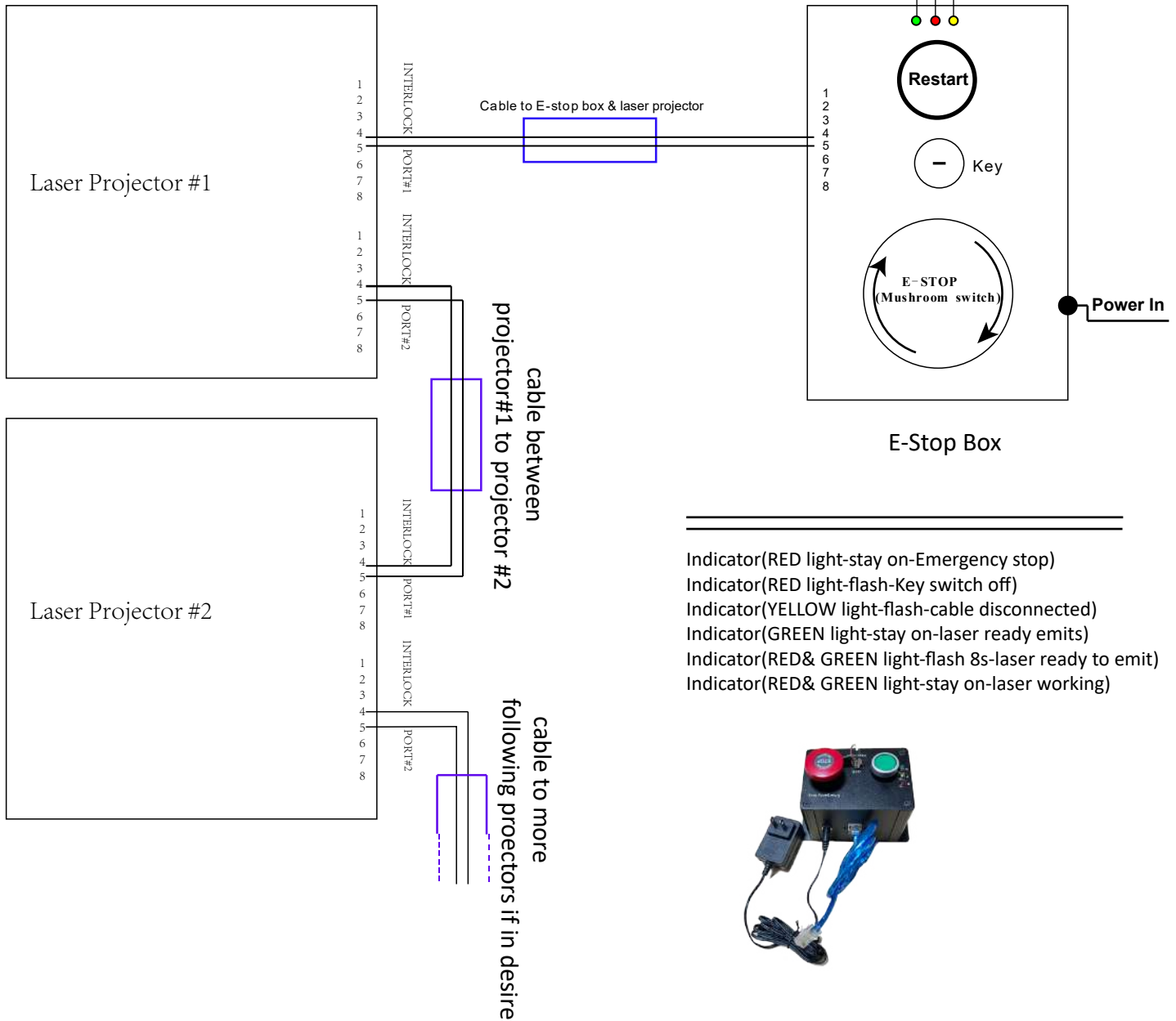

There may be a few models of the show systems that do not have the DUAL INTERLOCKS due to the limited space inside the compact size of the system to have the board assembled, therefore, remote interlock control in a low(daisy-chain) for them is not possible.

According to safety regulations in the US, CLASS 4 laser show systems must be equipped with the safety elements such as mechanical shutter plate to prevent a potential single laser beam shot.

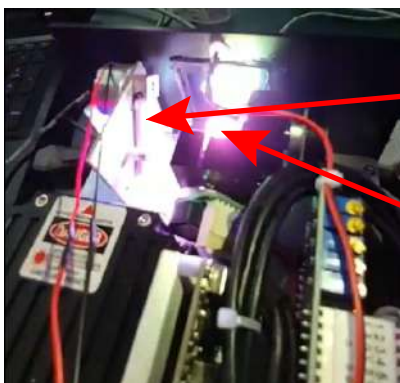

Mechanical shutter plate

Laser beams at Galvoscaner's mirrors

LCD Display Setting introductions

Indicators

a. Power supply and TF Card status indication:



OFF	Not powered
Slow flash	No TF Card
Always on	With TF Card

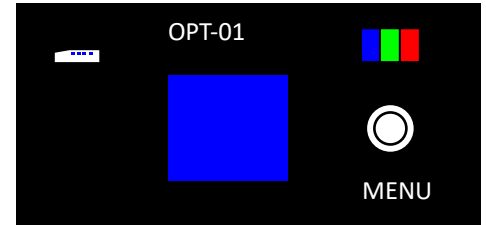

b. DMX status



OFF	Without DMX daughterboard Abnormal
Slow flash	DMX daughterboard loaded , but no DMX Signal
Always on	Normal DMX communication

c. Laser Output status



OFF	No output
Always on	Normal output

Note:

All the contents listed on the LCD display can be freely changed to the preferable status. The most important step is to “double-click” the menu knob to SAVE the preferred status when all selections/settings get done. (The other settings should be operated step by step as DMX setting reference as the guidance following)

MENU Content |Items

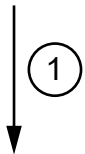

For instance, ZLDA display mode is chosen from “Operation Mode”

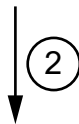

For instance, DMX512 display mode is chosen from “Operation Mode”

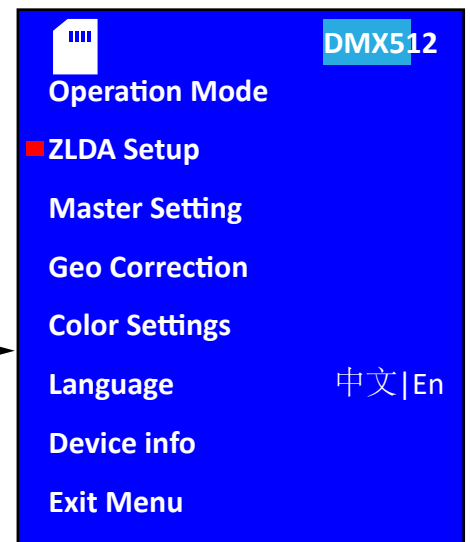
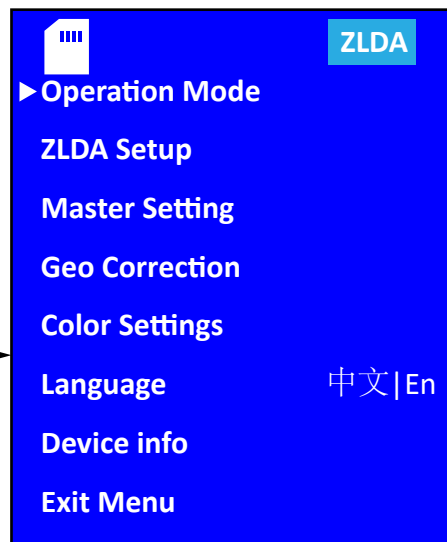
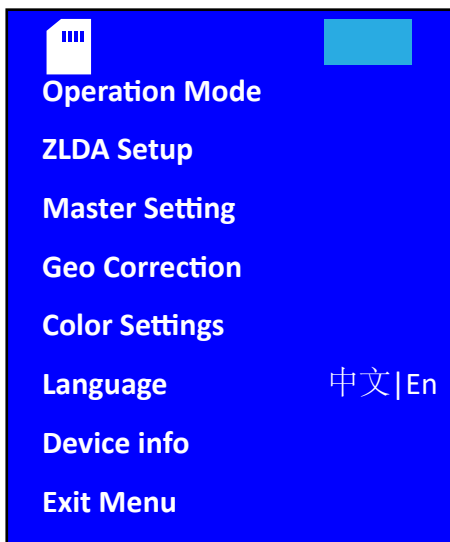
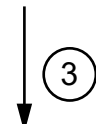

Remark area(the actual screen is without this colored background)

The real-time display mode status will be shown in this area, it can be any mode under the content Operation Mode such as ZILDA or DMX512, etc.

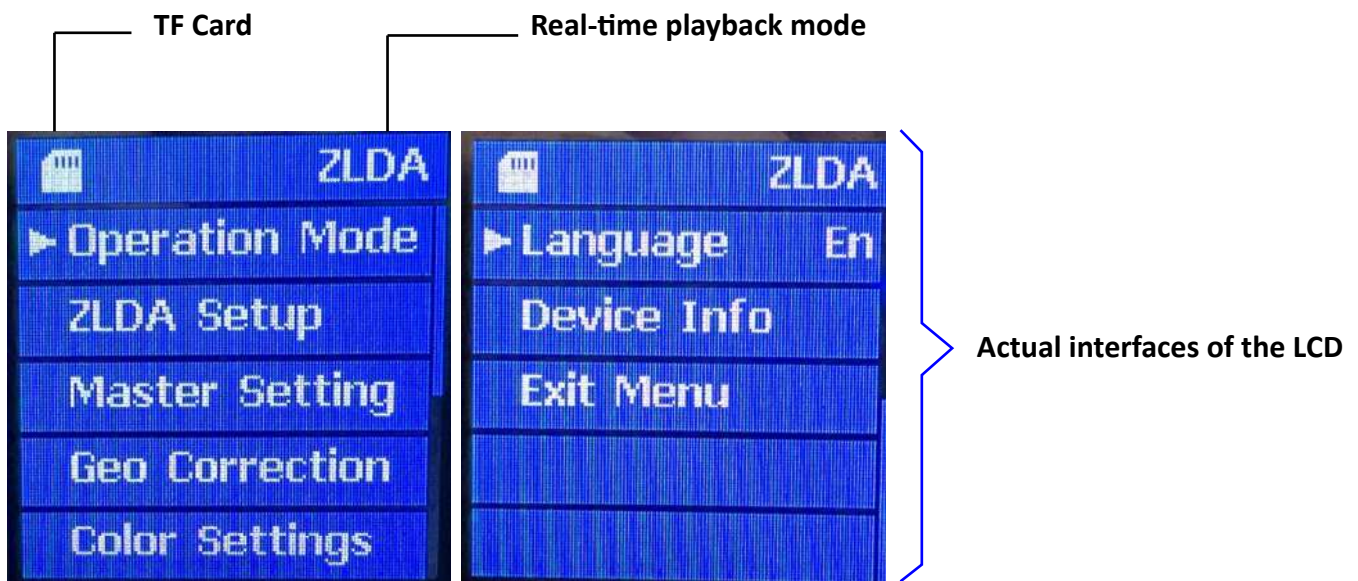

The Overall menu's content

	Operation Mode
	ZLDA Setup
	Master Setting
	Geo Correction
	Color Settings
	Language En
	Device info
	Exit Menu

Menu Item	Description
Operation Mode	Select the playback method, including [DMX512], [ILDA], [ZLDA], [TEST] and [DAC] and other playback mode
ZLAD Setup	Settings corresponding to the selected playback mode
Master Setting	Basic settings of the system
Geo Correction	Orientation parameter settings Geo correction
Color settings	Color parameter settings
Language	Chinese Simplified Chinese En English
Device Info	Device version and other information
Exit menu	Save settings and turn off backlight

Master Setting

Master Setting
Scan Rate
Color Shift
Rescan
Each Play
Turn Off Time
Animate Mode 1
Animate Rate 1
Target FPS 10
Single Prt
Interlock
Exit

Menu Item	Description	default value
Scan Rate	The number of points of laser output per second, range 5~40K	20
Color Shift	The number of points of the color lag coordinate, range 0~15 points	0
Rescan	After the playback source is disconnected, the duration before the program is turned off, unit millisecond, range 100~999ms	999
Each Play	The minimum playing time of each program, in seconds, range 1~20s	2
Turn Off Time	After there is no operation on the interface, the screen-off time, in seconds, ranges from 5 to 60s , 60s means the screen is always on	30
Animate Mode	1 —display as per points 2 —display as per frames	1
Animate Rate	This parameter is valid when display as per points is selected. 1 is full speed, 2 is 1/2 speed, 3 is 1/3 speed	1
Target FPS	If you choose to play by frame, this parameter is valid. The number of frames of the program played per second, frame range 1~40	10
Exit	Exit the current menu and return to the previous menu	

Selections of Operation Mode

Operation Mode
DMX512 ✗
ILDA Play ✗
ZLDA Play ✓
TEST Play ✗
RJ45 Play ✗
Exit

Menu Item	Description	default value
DMX512	DMX512 Control mode, program data comes from TF card, corresponding to the dmx\ directory ZLDA format file.	×
ILDA Play	ILDA Play, program data comes from TF ILDA under the ilda\ directory in the card format file.	×
ZLDA Play	ZLDA Play, program data comes from TF ZLDA under the zlda\ directory in the card format file.	×
TEST Play	TEST Play, program data comes from TF ZLDA in the test\ directory in the card format file.	×
Exit	Exit the current menu and return to the previous menu.	

Geo Correction

Geo Correction
Master Size 100
X Scale 100
Y Scale 100
X Shear 0
Y Shear 0
Z angle 0
X Position 0
Y Position 0
X Invert ✗
Y Invert ✗
XY Swap ✗
Exit

Menu Item	Description	default value
Master Size	0~100%	50
X Scale	0~100%	100
Y Scale	0~100%	100
X Shear	- 100~100%	0
Y Shear	- 100~100%	0
Z Angle	0~359	0
X Position	- 100~100%	0
Y Position	- 100~100%	0
X Invert	0 1 0-Positive, 1-Reverse	x
Y Invert	0 1 0-Positive, 1-Reverse	x
XY Swap	0 1	x
Exit	Exit the current menu and return to the previous menu	

ZLDA Setup

Sub-menu

Play Mode
File Index
End Action
Exit

Menu Item	Description	default value
Play mode	[Cue] Means only one laser cue will be displayed in loop, corresponding to ZLDA in the ilda\cue\ directory format file . [List] Presents the playlist file, corresponding to ZLDA in the ilda\list\001~999\ directory grid format file. [None] No output	single
File Index	The number of files currently being played, from 001 to 999 . Select [Single] for playback mode, which means 001.zld~999.zld in the zlda\cue\ directory Select [List] for the playback mode, which means the files in the 001\~999\ directory under the zlda\list\ directory.	001
End Action	[Loop] After the program reaches the end, it will start playing from the beginning. [Stop] After the program reaches the end, turn off the laser output.	cycle
Exit	Exit the current menu and return to the previous menu	

Wiring guidelines for the LCD display



Power connections

Pin	name	Voltage
1	GND	0
2	VCC	+7V ~ +24V

DMX input

Pin	name	Voltage
1	GND	0
2	DMX RX	— —
3	DMX Tx	— —
4	I2C SCL	— —
5	I2C SDA	— —
6	I2C INT	— —
7	VCC	3.3V



ILDA Input

Pin	name	Voltage
1	GND	0
2	HAS	ground
3	EN	ground
4	GND	0
5	B IN	0 ~ +5V
6	G IN	0 ~ +5V
7	R IN	0 ~ +5V
8	GND	0
9	YIN-	-5V ~ +5V
10	YIN+	-5V ~ +5V
11	XIN-	-5V ~ +5V
12	XIN+	-5V ~ +5V

RGB output

Pin	name	Voltage
1	Red	0 ~ +5V
2	Green	0 ~ +5V
3	Blue	0 ~ +5V
4	Deep Blue	0 ~ +5V
5	Yellow	0 ~ +5V
6	Cyan	0 ~ +5V
7	Shutter	— —
8	GND	0

GS Output

Pin	name	Voltage
1	Y+	-5V ~ +5V
2	Y-	-5V ~ +5V
3	GND	0
4	GND	0
5	X-	-5V ~ +5V
6	X+	-5V ~ +5V

PR5 SERIES

Standard Versions (without FB4 built-in)

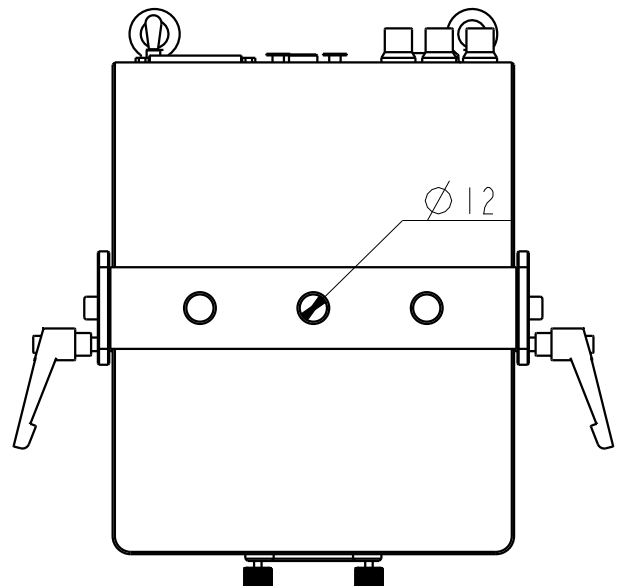
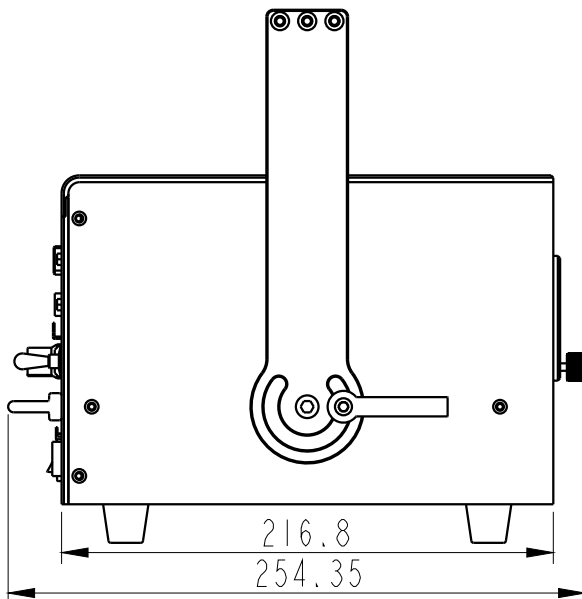
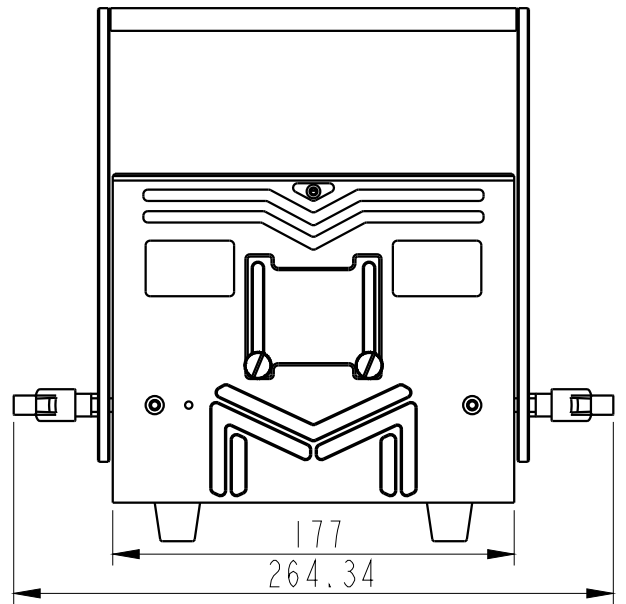
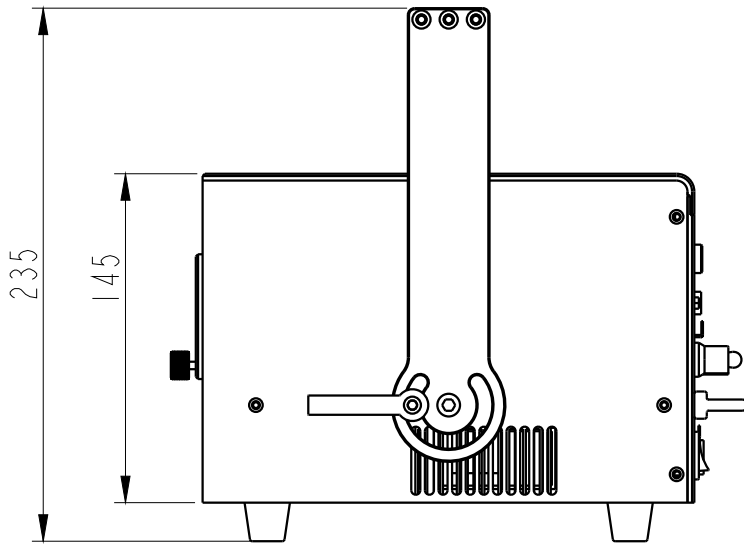
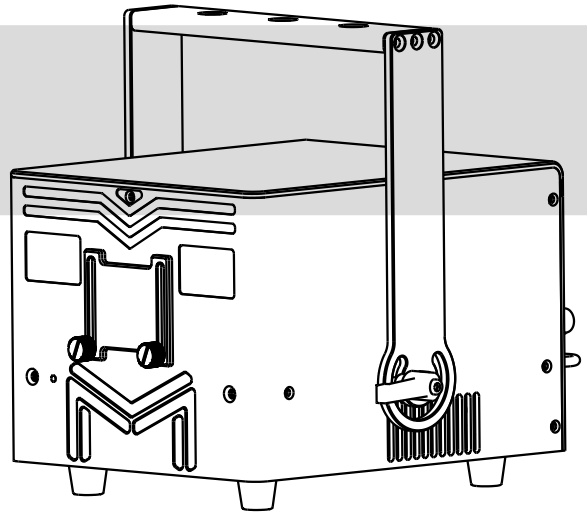

INTRODUCTIONS of PR5 SERIES

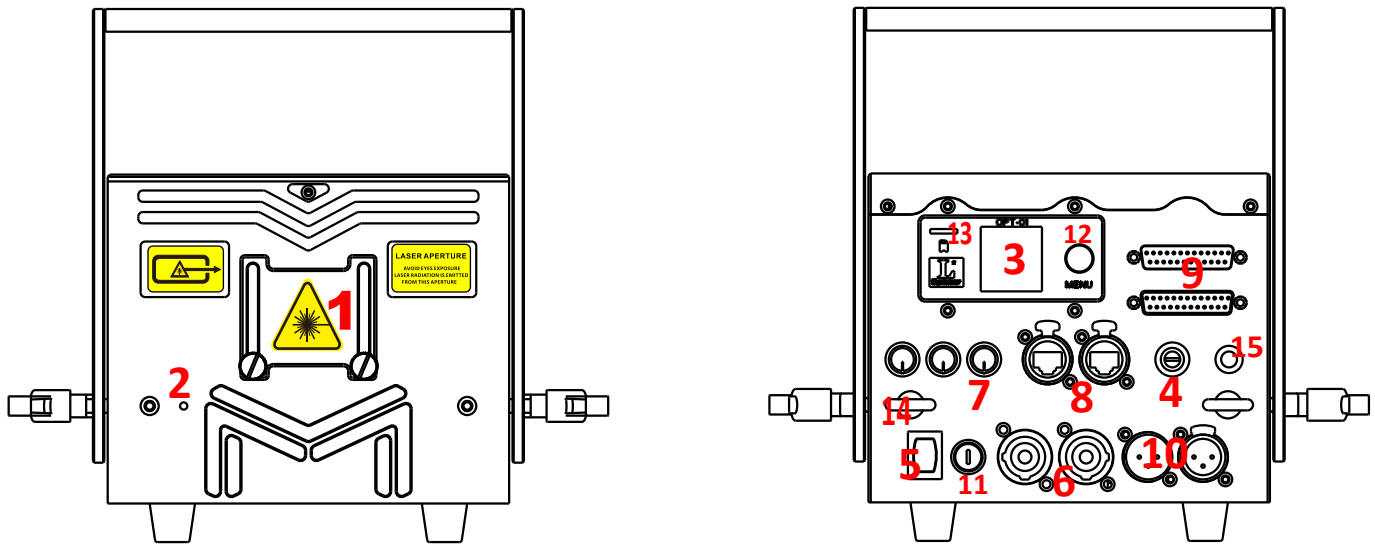

1	Laser aperture	(covered by masking plate) DO NOT look directly into this aperture once the masking plate gets loosen
2	Laser Emission	When this indicator is lit up the laser system is ready to emit the laser radiation as soon as it receives instructions from control software.
3	LCD Display	Integrated with multi settings on the projector, please refer to detailed settings (on Page 11.) for the LCD
4	Keyhole	Safety key, laser output is available when the key is moved to position “on”
5	Power Switch	Power On/Off
6	PowerCON Input & Output	Power connections input and output
7	Color intensity knobs	R/G/B power intensity adjustments, rotate or anti-rotate to adjust output power
8	INTERLOCK (RJ45 jack)	Laser output is available only when the interlock is connected. It could be used to connect a laser emergency switch(E-stop box).
9	ILDA Input & Output	DB25 connections input and output for ILDA mode display
10	DMX Input & Output	3-pin DMX connections input and thru for DMX512 mode display
11	FUSE	Safety element; current rating 8amps
12	Menu knob for LCD Setting	The knob for the main settings on LCD, click it to wake the LCD and rotate it for corresponding status setting
13	SD-Card Slot	Slot for SD-Card which you may have your own laser files to export on
14	Safety Ring	The ring for enwinding a safety rope when the laser device will be installed on out-of-reach locations.
15	SFS	Scan-fail safety switch



Specifications of PR5 SERIES

Type of Laser	Pure diode-based full colors(semiconductor diode laser systems)																									
Laser Classification	Class 4																									
Laser Power(mW)	<table border="1"> <thead> <tr> <th>Model</th> <th>λ</th> <th>638nm</th> <th>520nm</th> <th>445nm or 465nm</th> </tr> </thead> <tbody> <tr> <td>PR3000A-RGB</td> <td>R/</td> <td>700mW+G/1000mW+B/1600mW</td> <td></td> <td></td> </tr> <tr> <td>PR4000A-RGB</td> <td>R/</td> <td>1000mW+G/1000mW+B/2000mW</td> <td></td> <td></td> </tr> <tr> <td>PR6000A-RGB</td> <td>R/</td> <td>1950mW+G/2000mW+B/2000mW</td> <td></td> <td></td> </tr> <tr> <td>PR8000A-RGB</td> <td>R/</td> <td>1950mW+G/2400mW+B/4000mW</td> <td></td> <td></td> </tr> </tbody> </table>	Model	λ	638nm	520nm	445nm or 465nm	PR3000A-RGB	R/	700mW+G/1000mW+B/1600mW			PR4000A-RGB	R/	1000mW+G/1000mW+B/2000mW			PR6000A-RGB	R/	1950mW+G/2000mW+B/2000mW			PR8000A-RGB	R/	1950mW+G/2400mW+B/4000mW		
Model	λ	638nm	520nm	445nm or 465nm																						
PR3000A-RGB	R/	700mW+G/1000mW+B/1600mW																								
PR4000A-RGB	R/	1000mW+G/1000mW+B/2000mW																								
PR6000A-RGB	R/	1950mW+G/2000mW+B/2000mW																								
PR8000A-RGB	R/	1950mW+G/2400mW+B/4000mW																								
Scanning-system	40kpps ILDA@8° , Scan angle Max 60°																									
Beam Size@aperture	3.0*6.0 mm																									
Beam Divergence	<1.2mRad																									
Modulation	>100 KHz																									
Power Supply	AC 100-240V, 50/60Hz																									
Power Consumption	70 75 85 90W																									
Net Weight	4.80kg																									
Dimension	254*177*145mm																									
Controls	Auto[ZLDA], DMX512 , ILDA																									
Operation Temperature	minus 20℃ to 40℃																									
Protection Rating	IP54																									
Safety elements	Keyed interlock, emission delay, magnetic interlock, scan-fail safety, mechanical shutter, adjustable aperture masking plate.																									
Important statement	Due to Advanced Optical Correction technology used in our laser systems the optical power output of each laser colour within the system may slightly differ from the specification of respective laser module(s) installed. This does not affect the total guaranteed power output.																									

PR10 SERIES

Standard Versions(without FB4 built-in)

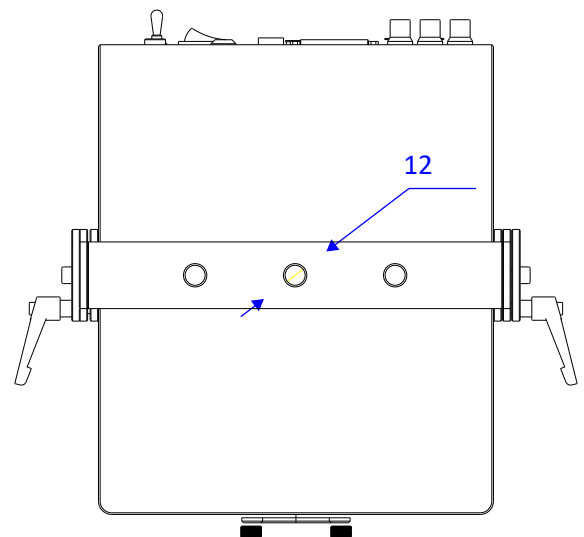
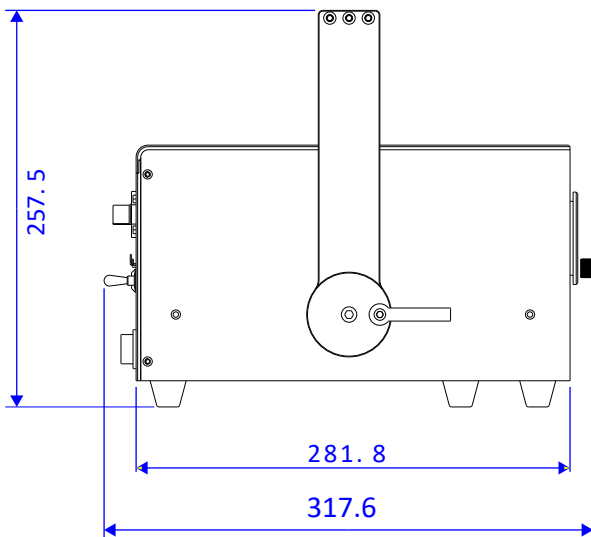
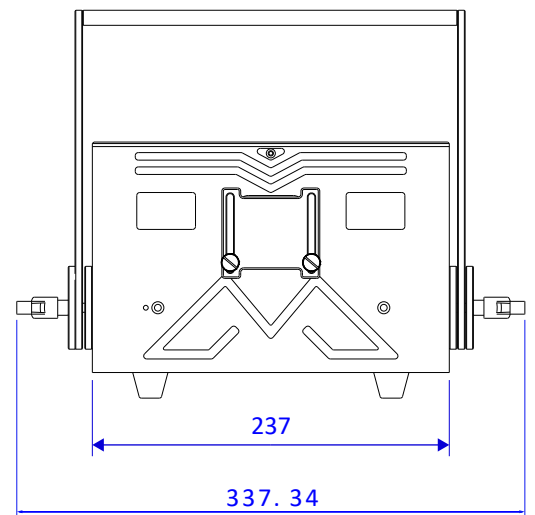
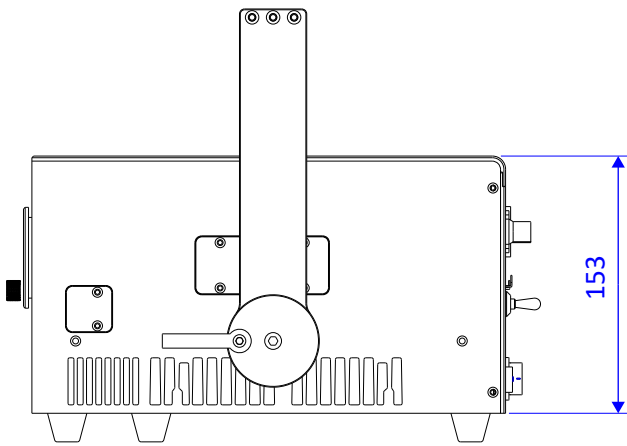
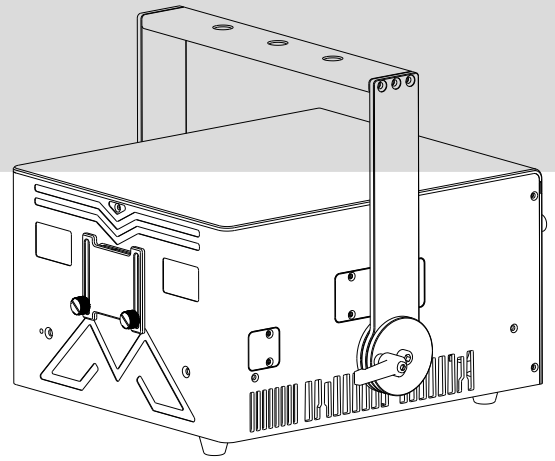

INTRODUCTIONS of PR10 SERIES

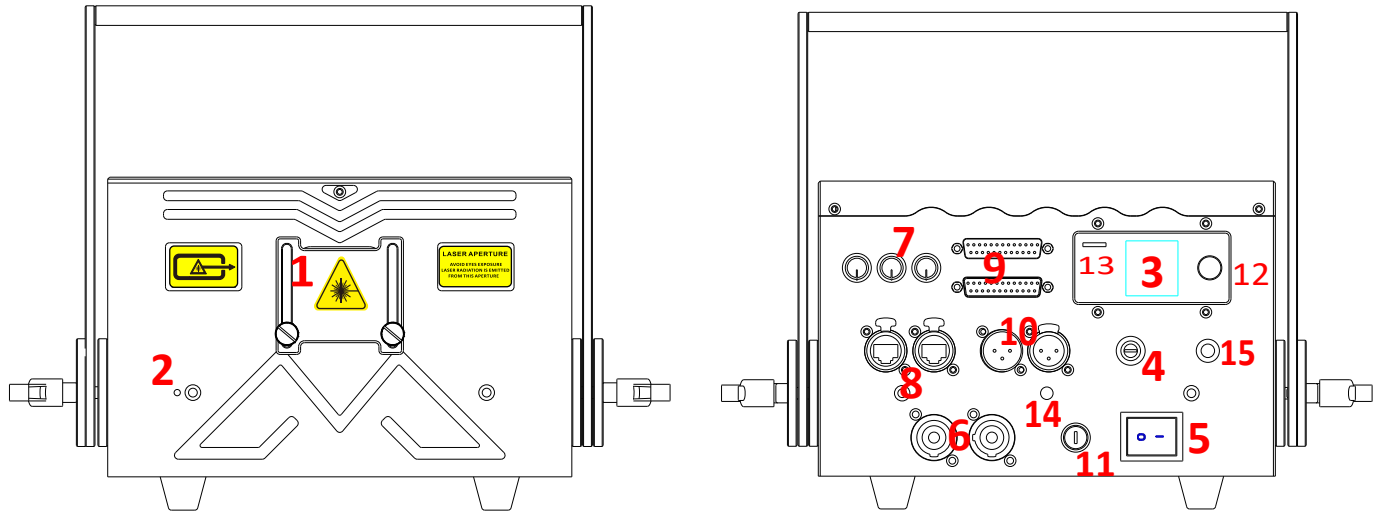

1	Laser aperture	(covered by masking plate) DO NOT look directly into this aperture once the masking plate gets loosen
2	Laser Emission	When this indicator is lit up the laser system is ready to emit the laser radiation as soon as it receives instructions from control software.
3	LCD Display	Integrated with multi settings on the projector, please refer to detailed settings (on Page 11.) for the LCD
4	Keyhole	Safety key, laser output is available when the key is moved to position “on”
5	Power Switch	Power On/Off
6	PowerCON Input & Output	Power connections input and output
7	Color intensity knobs	R/G/B power intensity adjustments, rotate or anti-rotate to adjust output power
8	INTERLOCK (RJ45 jack)	Laser output is available only when the interlock is connected. It could be used to connect a laser emergency switch(E-stop box).
9	ILDA Input & Output	DB25 connections input and output for ILDA mode display
10	DMX Input & Output	3-pin DMX connections input and thru for DMX512 mode display
11	FUSE	Safety element; current rating 8amps
12	Menu knob for LCD Setting	The knob for the main settings on LCD, click it to wake the LCD and rotate it for corresponding status setting
13	SD-Card Slot	Slot for SD-Card which you may have your own laser files to export on
14	Safety Ring	The ring for enwinding a safety rope when the laser device will be installed on out-of-reach locations.
15	SFS	Scan-fail safety switch



Specifications of PR10 SERIES

Type of Laser	Pure diode-based full colors(semiconductor diode laser systems)																									
Laser Classification	Class 4																									
Laser Power(mW)	<table border="1"> <thead> <tr> <th>Model</th> <th>λ</th> <th>638nm</th> <th>520nm</th> <th>445nm or 465nm</th> </tr> </thead> <tbody> <tr> <td>PR14000-RGB</td> <td>R/4200mW+G/4800mW+B/5500mW(445nm)</td> <td></td> <td></td> <td></td> </tr> <tr> <td>PR13000-RGB</td> <td>R/4200mW+G/4600mW+B/4500mW(465nm)</td> <td></td> <td></td> <td></td> </tr> <tr> <td>PR10000-RGB</td> <td>R/2800mW+G/3200mW+B/5000mW(445nm)</td> <td></td> <td></td> <td></td> </tr> <tr> <td>PR9000-RGB</td> <td>R/2800mW+G/3200mW+B/3000mW(465nm)</td> <td></td> <td></td> <td></td> </tr> </tbody> </table>	Model	λ	638nm	520nm	445nm or 465nm	PR14000-RGB	R/4200mW+G/4800mW+B/5500mW(445nm)				PR13000-RGB	R/4200mW+G/4600mW+B/4500mW(465nm)				PR10000-RGB	R/2800mW+G/3200mW+B/5000mW(445nm)				PR9000-RGB	R/2800mW+G/3200mW+B/3000mW(465nm)			
Model	λ	638nm	520nm	445nm or 465nm																						
PR14000-RGB	R/4200mW+G/4800mW+B/5500mW(445nm)																									
PR13000-RGB	R/4200mW+G/4600mW+B/4500mW(465nm)																									
PR10000-RGB	R/2800mW+G/3200mW+B/5000mW(445nm)																									
PR9000-RGB	R/2800mW+G/3200mW+B/3000mW(465nm)																									
Scanning-system	40kpps ILDA@8° , Scan angle Max 60°																									
Beam Size@aperture	3.5*7.0 mm																									
Beam Divergence	<1.0 mRad																									
Modulation	>100 KHz																									
Power Supply	AC 100-240V, 50/60Hz																									
Power Consumption	170 175 185 210W																									
Net Weight	9.6kg																									
Dimension	313*237*153mm																									
Controls	Auto[ZLDA], DMX512 , ILDA																									
Operation Temperature	minus 20°C to 40°C																									
Protection Rating	IP54																									
Safety elements	Keyed interlock, emission delay, magnetic interlock, scan-fail safety, mechanical shutter, adjustable aperture masking plate.																									
Important statement	Due to Advanced Optical Correction technology used in our laser systems the optical power output of each laser colour within the system may slightly differ from the specification of respective laser module(s) installed. This does not affect the total guaranteed power output.																									

CF20 | CF30 SERIES

Standard Versions(without FB4 built-in)

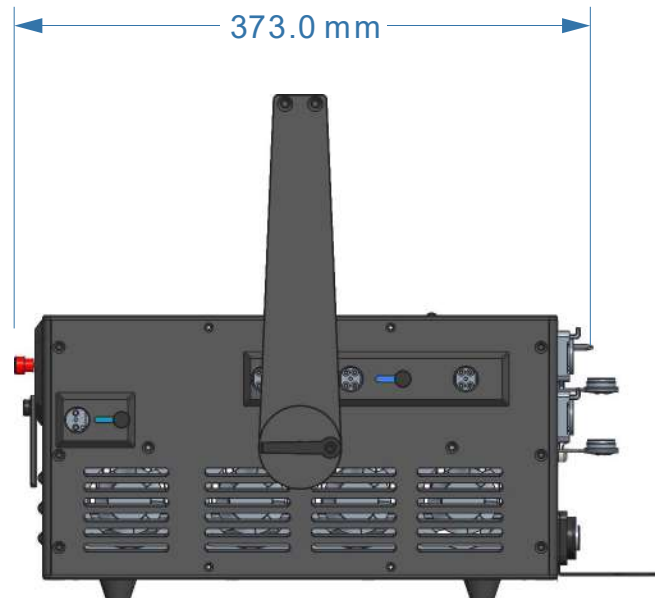
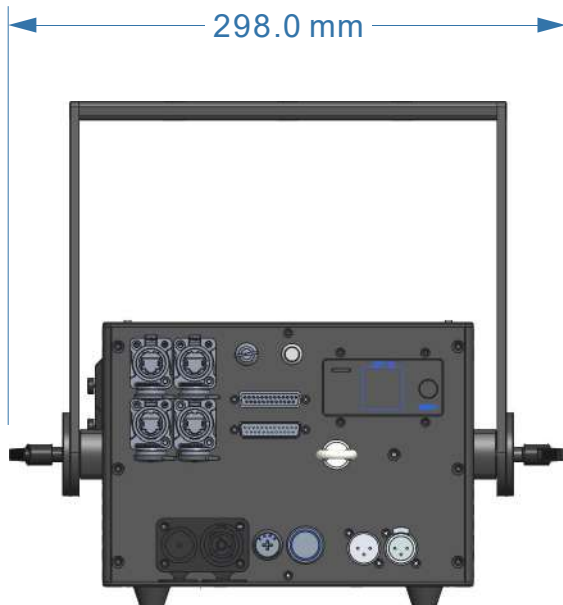
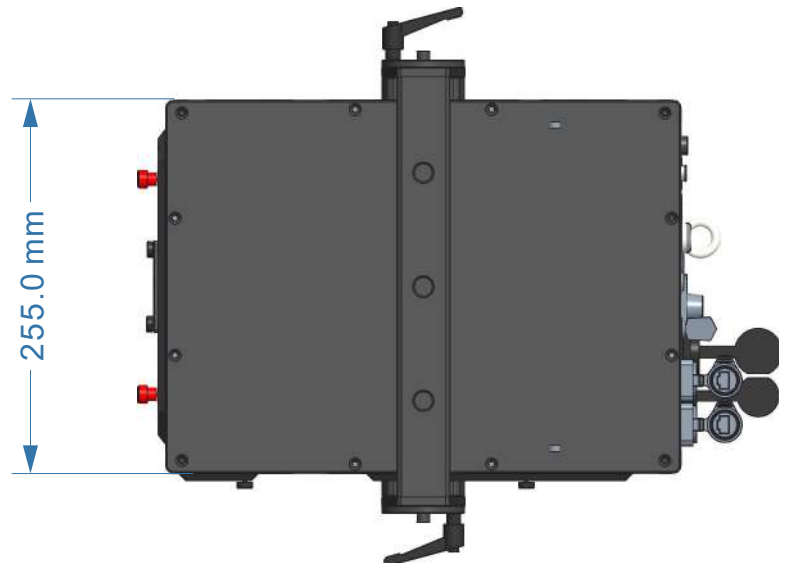
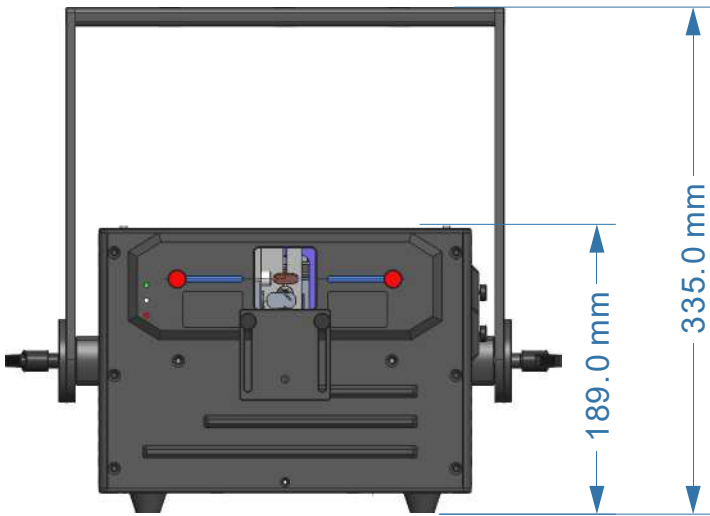

INTRODUCTIONS of CF20 | CF30 SERIES

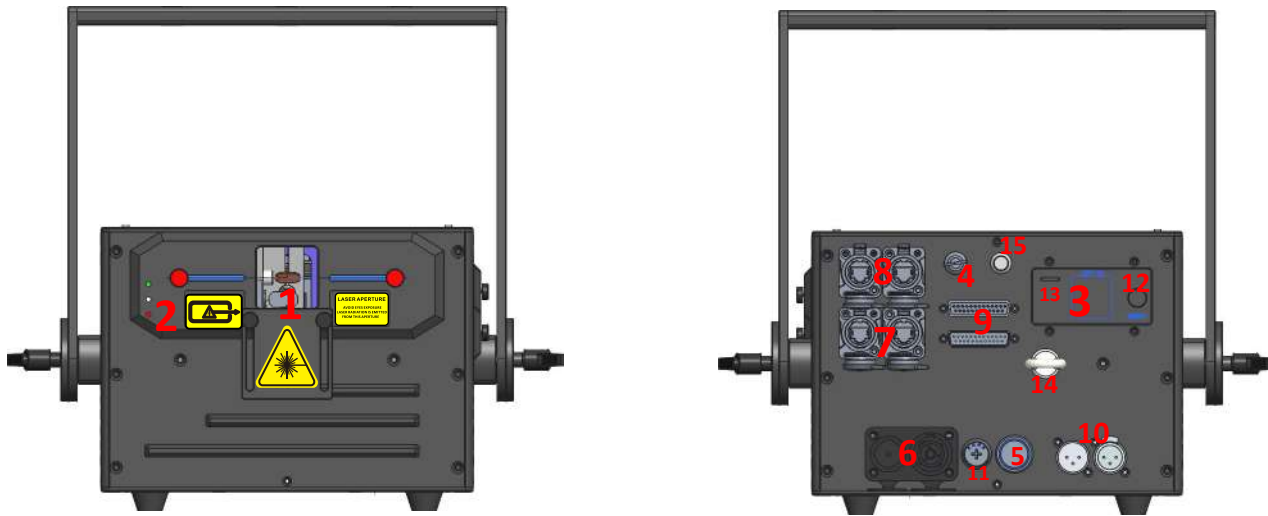

1	Laser aperture	(covered by masking plate) DO NOT look directly into this aperture once the masking plate gets loosen
2	Laser Emission	When the red indicator is lit up the laser system is ready to emit the laser radiation as soon as it receives instructions from control board or software.
3	LCD Display	Integrated with multi settings on the projector, please refer to detailed settings (on Page 11.) for the LCD
4	Keyhole	Safety key, laser output is available when the key is moved to position “on”
5	Power Switch	Power On/Off
6	PowerCON Input & Output	Power connections input and output
7	ILDA-RJ45 Jacks	The RJ45 adapter that signal is converted from standard ILDA board, for the purpose of flexible cabling on gigs if ILDA cables are not preferred.
8	INTERLOCK (RJ45 jack)	Laser output is available only when the interlock is connected. It could be used to connect a laser emergency switch(E-stop box).
9	ILDA Input & Output	DB25 connections input and output for ILDA mode display
10	DMX Input & Output	3-pin DMX connections input and thru for DMX512 mode display
11	FUSE	Safety element; current rating 8amps
12	Menu knob for LCD Setting	The knob for the main settings on LCD, click it to wake the LCD and rotate it for corresponding status setting
13	SD-Card Slot	Slot for SD-Card which you may have your own laser files to export on
14	Safety Ring	The ring for enwinding a safety rope when the laser device will be installed on out-of-reach locations.
15	SFS	Scan-fail safety switch

★ Specifications of CF20 | 30 SERIES

Type of Laser	Pure diode-based full colors(semiconductor diode laser systems)																				
Laser Classification	Class 4																				
Laser Power(mW)	<table border="1"> <thead> <tr> <th>Model</th> <th>λ</th> <th>638nm</th> <th>520nm</th> <th>445nm or 465nm</th> </tr> </thead> <tbody> <tr> <td>CF30000-RGB</td> <td>R/8000mW+G/10000mW+B/12000mW</td> <td></td> <td></td> <td></td> </tr> <tr> <td>CF24000-RGB</td> <td>R/7000mW+G/8000mW+B/9000mW</td> <td></td> <td></td> <td></td> </tr> <tr> <td>CF20000-RGB</td> <td>R/5600mW+G/6000mW+B/8500mW</td> <td></td> <td></td> <td></td> </tr> </tbody> </table> 	Model	λ	638nm	520nm	445nm or 465nm	CF30000-RGB	R/8000mW+G/10000mW+B/12000mW				CF24000-RGB	R/7000mW+G/8000mW+B/9000mW				CF20000-RGB	R/5600mW+G/6000mW+B/8500mW			
Model	λ	638nm	520nm	445nm or 465nm																	
CF30000-RGB	R/8000mW+G/10000mW+B/12000mW																				
CF24000-RGB	R/7000mW+G/8000mW+B/9000mW																				
CF20000-RGB	R/5600mW+G/6000mW+B/8500mW																				
Scanning-system	40kpps ILDA@8° , Scan angle Max 60°																				
Beam Size@aperture	5.0*7.0 mm																				
Beam Divergence	<1.0mRad																				
Modulation	>100 KHz																				
Power Supply	AC 100-240V, 50/60Hz																				
Power Consumption	300 350 400																				
Net Weight	12.80kg 14.60kg																				
Dimension	373*270*211mm																				
Controls	Auto[ZLDA], DMX512 , ILDA																				
Operation Temperature	minus 20℃ to 40℃																				
Protection Rating	IP54																				
Safety elements	Interlock, emission delay, magnetic interlock, scan-fail safety, mechanical shutter, adjustable aperture masking plate.																				
Important statement	Due to Advanced Optical Correction technology used in our laser systems the optical power output of each laser colour within the system may slightly differ from the specification of respective laser module(s) installed. This does not affect the total guaranteed power output.																				

Display mode introduction

- *Audio Mode(Sound mode): Preset programs triggered by sound, any proper sound will enable laser to output.
- *Auto Mode: The preset programs automatically display in Auto mode.
- *Prg Mode(SD playback in order): The preset/exported programs playback in sequence. Redact of the playlist please refer to **SD Card Introduction**.
- *ILD Mode(SD loop playback): Loop playback the single ILD file (extension named .ILD).
About .ILD format, please refer to **SD Card Introduction**.

Notice: the ILD here refers to playing the ILD file in the SD card, not the ILDA signal though software on computer.

DMX Mode: International standard DMX512 signal. In any of the above playback modes, the device can automatically recognize and switch to DMX mode after accessing DMX signal. The device has 17 DMX channels. Refer to DMX Table for details.

DMX consoles vary in different manufacturers' models. Please refer to the specific DMX console instructions.

ILDA (PC) mode: International standard ILDA signal is under computer control. In any of the above operating modes, when an ILDA signal with an interlock function is connected, the ILDA(computer) signal control has priority and the device will be displaying laser cues, programs in accordance to the ILDA signal output from laser controller on the PC.

In ILDA mode, a control hardware will be required, the recommended one should be FB3 controller from Pangolin, yet we can also provide this part with fair cost when purchase laser systems from here.

The ILDA software(laser controller) has different operating methods from different manufacturers. Please refer to the specific ILDA software instructions, to our experience the most commonly and widely being used is QuickShow from Pangolin.com.

SD Card Introduction

- *The system accepts only FAT32 file, formatting the new SD card to FAT32 type is required before use it.
- *Short file / File folder names , the file names is limited to 8 digits and the expanded name is limited with 3 digits, the names could only contain English letters, Arabic numbers, and underline, the others could not be recognized.
- *Equipped an exclusive SD card for the device and don't save the other files inside; the quantity for the file folders is limited with 20, and each file folder is limited to contain 256 ILD files and 10 PRG files at maximum.
- *PRG playlist: user could edit the playlist by text editor, the expanded name of the playlist is .PRG format.
The playlist is constituted by file name, play speed, and play times, "i" is the identification code stand for iShow, and comma "," is used to separate it.

Edit only one program each line; for example, if a program prg1.prg contains 3 files:

file1.ild,

file2.ild,

and file3.ild; play speed for file1.ild is 12K and repeated 3 times; play speed for file2.ild is

20k and play once, the file 2 was produced by iShow; play speed for file3.ild is 18K and

repeated 4 times; and the contents of the prg1.prg is as below:

File1.ild,12,3

File2.ild,20,1,i

File3.ild,18,4

- *After creating a file folder, do create a PRG file under this file folder by the same file name, and edit all the playing files into this PRG file, the speed edited here is the play speed in ILDA mode. For Example, create the file folder "Lasershow", and create the file "Lasershow.prg" under this folder; after adding a new ILDA file, we need to add this ILDA file to this PRG playlist, so that we could find this file correctly in the ILDA mode and play it by required speed

DMX Charts

16 CHs

CH	Value	Descriptions	Width
1	0-255 _ DMX model	0-31 _ Close the light 33-95 _ Top 4 channels 97-159 _ Top 8 channels 161-232 _ Top 12 channels 225-255 _ Top 16 channels	8 Bit
2	0-255 _ Page index (9 in total Page)	0-15 _ Page 1 17-31 _ Page 2 33-47 _ Page 3 49-63 _ Page 4 65-79 _ Page 5 81-95 _ Page 6 97-111 _ Page 7 113-127 _ Page 8 129-255 _ Page 9	8 Bit
3	0-255 _ program index (48 in total programme)	0-32 _ Close the light 33-35 _ Program 1 37-39 _ Program 2 .. - 221-223 _ Program 48 225-255 _ — —	8 Bit
4	0-255 _ speed	0-15 _ Default speed 17-31 _ pause 33-255 _ 25% ~ 200%	8 Bit
5	0-255 _ brightness	0% ~ 100%	8 Bit
6	0-255 _ size	0%~ 100%	8 Bit
7	0-255 _ X size	-100% ~ 100%	8 Bit
8	0-255 _ Y size	-100% ~ 100%	8 Bit
9	0-255 _ Z angle	0~360 deg	8 Bit
10	0-255 _ X position	0 = left , 128 = center , 255 = right	8 Bit
11	0-255 _ Y position	0 = top , 128 = mid , 255 = bottom	8 Bit
12	0-255 _ Visible point	0 ~ 100%	8 Bit
13	0-255 _ scan rate	0-31 _ Default scan rate 33-223 _ 6K ~ 29K 225-255 _ 30K	8 Bit
14	0-255 _ reserve		8 Bit
15	0-255 color table	0-31 original color 33- 223 color table 225- 255 white	8 Bit
16	0-255 Reserved	Reserved	8 Bit

26 CHs

CH	Value	Description	Width
1	0-255 page index	page index , 0~3 light off 4~7 No. 1 Page 8~ 11 2nd Page 12~15 No. 3 Page ... 252~255 No. 63 Page	8 Bit
2	0-255 program index	program index 0~3 light off 4~7 No. 1 programme 8~ 11 2nd programme 12~15 No. 3 programme ... 252~255 No. 63 programme	8 Bit
3	0-255 playback speed	(0 = original speed , 1 – 255 = 1% ~ 255%)	8 Bit
4	0-255 brightness _	(0 ~ 100%)	8 Bit
5,6	0-65535 size	(0 ~ 100%)	16 Bit
7,8	0-65535X _ size	(-100 ~ 100%, 0 = 32768)	16 Bit
9,10	0-65535 Y size	(-100 ~ 100%, 0 = 32768)	16 Bit
11,12	0-65535 Z angle	Rotation angle (0~ 360 °)	16 Bit
13,14	0-65535Z _ rotate	Rotation speed -60 ~ 60 Rpm (0 = original position , 1 ~ 32767 = -100% ~ -1 % Rotation speed , 32768 = Save stationary and not rotating , 32769 ~ 65535 = 1% ~ 100% Rotating speed)	
15,16	0-65535X _ Location	(-100 ~ 100%, 0 = 32768)	16 Bit
17,18	0-65535 Y Location	(-100 ~ 100%, 0 = 32768)	16 Bit
19	0-255 scan rate	(5k ~ 30K)	8 Bit
20	0-255 red light brightness	(0 ~ 100%)	8 Bit
21	0-255 green light brightness	(0 ~ 100%)	8 Bit
22	0-255 blue light brightness	(0 ~ 100%)	8 Bit
23	0-255 RGB _ Change color	(0 = original color , 1-255 = 0 ~ 100% color change)	8 Bit
24	0-255 start display points	(0 ~ 100%)	8 Bit
25	0-255 end display point	(0 ~ 100%)	8 Bit
26	0-255 strobe _	0 = Turn off strobe 1-255 = 1 to 20 Hz	8 Bit

CH	Value	Description	Width
1	0-255 play mode	0-150 light off 150-190 setting mode 200-240 playback mode 240- 255 closed light	8 Bit
2	0-255 maximum brightness	Defines the maximum brightness used in playback mode (0 ~ 100%)	8 Bit
3	0--255 test pattern	(1= test program 1, 255 = test program 255)	8 Bit
4,5	0-65535X _ size	Defines the maximum width used in playback mode (-100 ~ 100%, 0 = 32768)	16 Bit
6,7	0-65535 Y _ size	Defines the maximum height used in playback mode (-100 ~ 100%, 0 = 32768)	16 Bit
8,9	0-65535X _ Location	Define the horizontal position in playback mode (-100 ~ 100%, 0 = 32768)	16 Bit
10,11	0-65535 Y Location	Defines the vertical position in playback mode (-100 ~ 100%, 0 = 32768)	16 Bit
12,13	0-65535 Z Rotation angle	Define the rotation angle in play mode (0~ 360 °)	16 Bit
14	0-255 page index	Page index , 1 = page 1 Page , 255 = Page 255 Page	8 Bit
15	0-255 program index	Program index , (1 = 1st program , 255 = 255th _ programme)	8 Bit
16	0-255 playback speed	(0 = original speed , 1 – 255 = 1% ~ 255%)	8 Bit
17	0-255 brightness _	(0 ~ 100%)	8 Bit
18,19	0-65535 size	(0 ~ 100%)	16 Bit
20,21	0-65535X _ size	(-100 ~ 100%, 0 = 32768)	16 Bit
22,23	0-65535 Y size	(-100 ~ 100%, 0 = 32768)	16 Bit
24,25	0-65535Z _ angle	Rotation angle (0~ 360 °)	16 Bit
26,27	0-65535 Z rotate	Rotation speed -60 ~ 60 Rpm (0 = original position , 1 ~ 32767 = -100% ~ -1 % Rotation speed , 32768 = Save stationary and not rotating , 32769 ~ 65535 = 1% ~ 100% Rotating speed)	
28,29	0-65535X _ Location	(-100 ~ 100%, 0 = 32768)	16 Bit
30,31	0-65535 Y Location	(-100 ~ 100%, 0 = 32768)	16 Bit
32	0-255 scan rate	(5k ~ 30K)	8 Bit
33	0-255 red light brightness	(0 ~ 100%)	8 Bit
34	0-255 green light brightness	(0 ~ 100%)	8 Bit
35	0-255 blue light brightness	(0 ~ 100%)	8 Bit
36	0-255 RGB _ Change color	(0 = original color , 1-255 = 0 ~ 100% color change)	8 Bit
37	0-255 start display points	(0 ~ 100%)	8 Bit
38	0-255 end display point	(0 ~ 100%)	8 Bit
39	0-255 strobe _	0 = Turn off strobe 1-255 = 1 to 20 Hz	8 Bit

Maintenance Instruction

The device is mostly installed in the location that there is dust, haze, and smoke, which are easily pollute the lens and decrease the output brightness; these particles also easily pollute the light case, fans, PCBA, block the heat dissipation, and reduce the stability of the electronic components; so the regular cleaning is very necessary and important to keep the maximum light output and increase the stability and lifetime. It is recommended to clean the window lens, outside case, and fans every 2 weeks, and clean the internal of the stage light every 4 weeks; the cleaning frequency should be higher in the severe working condition.

Note:

Only an qualified & authorized technician(s) is(are) allowed to clean the internal parts, improper operations for the internal cleaning could cause serious damage to the device. It is forbidden to use the corrosive chemicals to clean the device, the pure alcohol and acetone is recommended to clean the lens.

Clean the lens carefully and gently, don't touch the lens by any hard and sharp materials.

After sales service and warranty

* One year's warranty for the device.

* The components and accessories costs are charged after the warranty period.

*Warranty voids for the damages or injuries caused by force majeure, like, earthquake, typhoon, and so on.

*Warranty voids for the damages or injuries caused by improper operation and projection, such as wrong input voltage, water immerse, physical shock, and so on